

Lightwave Signal Analyzers Measure Relative Intensity Noise

Product Note 71400-1

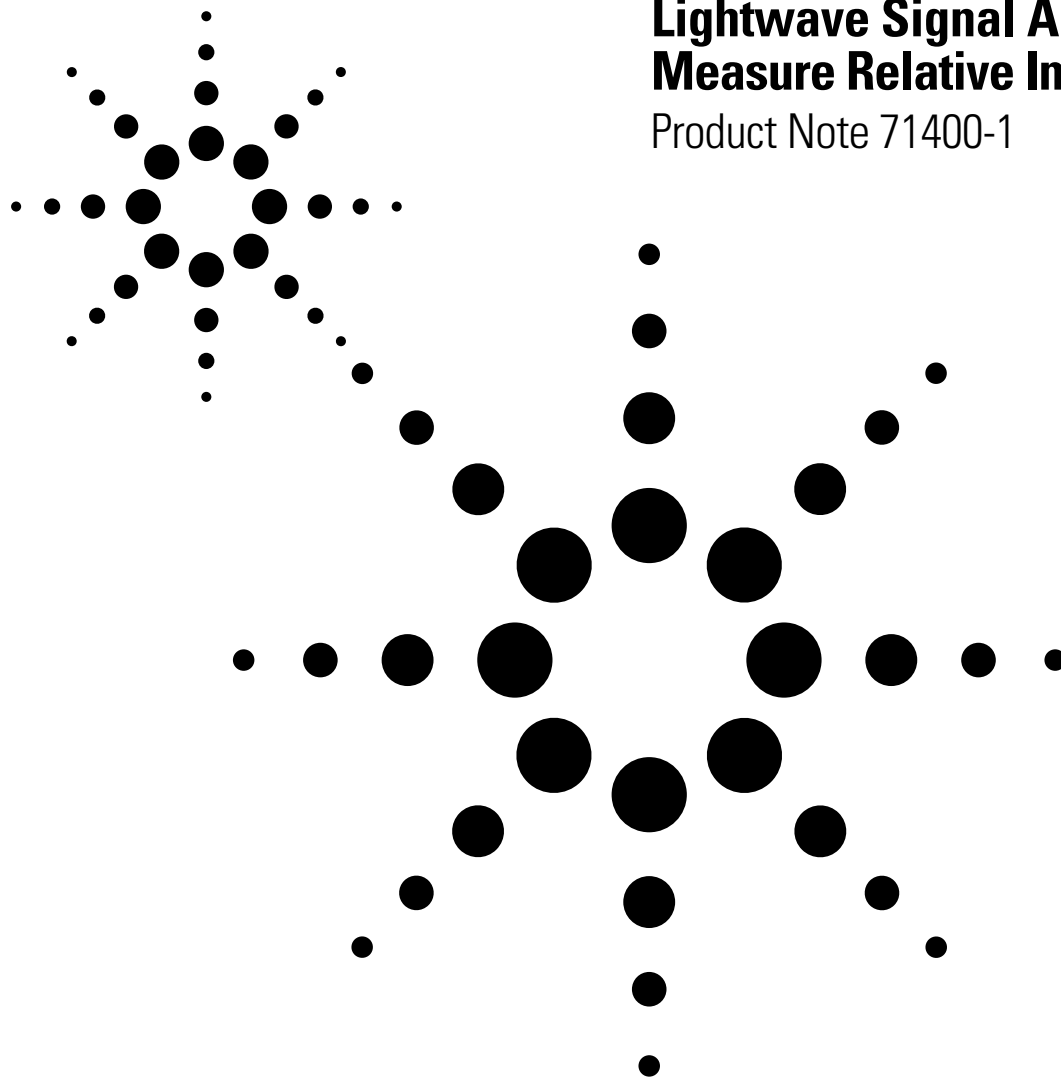

The Agilent 71400C and 71401C automatically subtract thermal and shot noise from RIN measurements

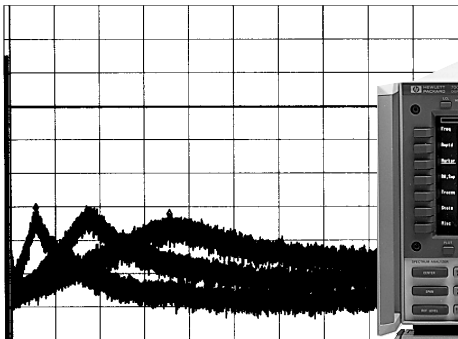

- Laser Intensity Noise
- RIN Definition
- RIN Measurement Limits
- Laser RIN Personality

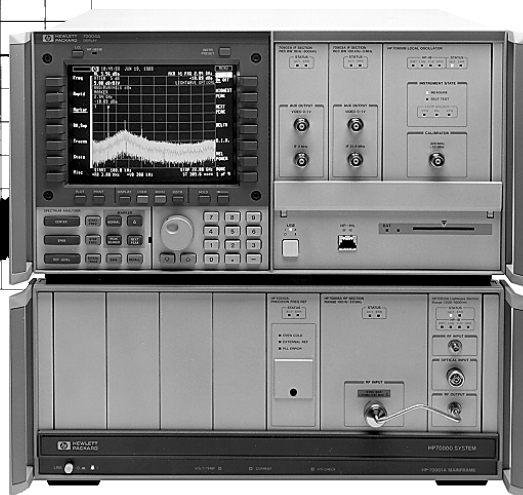

Agilent Technologies

Innovating the HP Way

Table of Contents

	Page
Introduction	3
Chapter 1. Measuring Laser Intensity Noise	4
Relative Intensity Noise	4
Noise Sources in a Fiber-Optic System	4
Thermal Noise	5
Shot Noise	5
Laser Intensity Noise	6
RIN Measurement Limitations	6
Finding RIN_{Laser} from RIN_{System}	7
Small Errors May Cause Large Effects	8
Summary	9
References	10
Chapter 2. Measure Relative Intensity Noise with the Agilent 71400C and 71401C	11
Agilent 71400C and 71401C Lightwave Signal Analyzers	11
The Agilent 70810B Lightwave Converter	11
Noise Measurements	12
Marker Noise	12
System RIN Measurements	12
Measurement Limits of RIN_{System}	13
Laser RIN Measurements	13
Measurement Limits of RIN_{Laser}	14
RIN Variability	15
Using the Personality	15
Example 1: DFB	16
Example 2: DFB laser	17
Example 3: Mini-YAG	17
Appendix A. Electrical-Optical Relationships	18
Relationship Between Optical and Electrical Powers	18
Appendix B. Personality Installation and Removal	19
What is a Measurement Personality?	19
System Requirements	19
Reloading the Personality from the ROM Card	19
Retrieving the DLP Execute Key from a User Overwrite	20
Erasing a DLP from the Instrument's Memory	20
Reloading the Personality from the Floppy Disk	21
Appendix C. RIN Remote Commands	22
Example:	23

Introduction

As high-speed fiber-optic communication becomes increasingly important, so does the need to perform precision measurements on lasers and lightwave systems. Laser intensity noise is one of the limiting factors in the transmission of analog or digital signals over fiber and must be characterized. Intensity noise, or power fluctuations in the lightwave signal, reduces signal-to-noise ratios (S/N) and increases bit error rates. Intensity noise degrades performance in high-speed direct-detection systems, thereby increasing the need for repeaters or optical amplifiers in long distance transmissions. At the same time, however, noise limits the number of repeaters that can be added to a distribution system.

This product note describes techniques to measure laser intensity noise with the Agilent 71400C and 71401C lightwave signal analyzers. Chapter 1 defines relative intensity noise (RIN) and describes the contributions of laser, thermal, and shot noise to the total system noise. Chapter 2 describes the RIN measurement functions available in the Agilent 71400C. Measurement examples are included that illustrate RIN measurements with and without the shot-noise and thermal noise contributions. Also covered is the operation of a downloadable program that determines the RIN of only the laser by subtracting the thermal noise of the analyzer and the shot noise of the photodiode.

Chapter 1

Measuring Laser Intensity Noise

Relative Intensity Noise

The measurement of relative intensity noise (RIN) describes the laser's maximum available amplitude range for signal modulation and serves as a quality indicator of laser devices. RIN can be thought of as a type of inverse carrier-to-noise-ratio measurement.

RIN is the ratio of the mean-square optical intensity noise to the square of the average optical power:^{1,2}

$$\text{RIN} = \frac{\langle \Delta P^2 \rangle}{P^2} \text{ dB/Hz ;} \quad (1)$$

where: $\langle \Delta P^2 \rangle$ is the mean-square optical intensity fluctuation (in a 1-Hz bandwidth) at a specified frequency, and P is the average optical power.

The ratio of optical powers squared is equivalent to the ratio of the detected electrical powers. Thus, RIN can be expressed in terms of detected electrical powers. Equation 1 can be rewritten as:

$$\text{RIN} = \frac{N_{\text{elec}}}{P_{\text{AVG}(\text{elec})}} \text{ dB/Hz} \quad (2)$$

where: N_{elec} is the power spectral density of the photocurrent at a specific frequency, and $P_{\text{AVG}(\text{elec})}$ is the average power of the photocurrent.

The photonic shot noise is not included in the definition of N_{elec} .³ From this point on, the (elec) subscript will be dropped, and all terms will be presented in electrical units unless noted by an optical subscript.

Noise Sources in a Fiber-Optic System

A typical optical receiver consists of a photodetector and amplification. The noise at the receiver output results from three fundamental contributions: laser intensity noise primarily due to spontaneous light emissions; thermal noise from the electronics; and photonic shot noise. The total system noise, $N_T(f)$, is the linear summation of these three noise sources.

$$N_T(f) = N_L(f) + N_q + N_{\text{th}}(f) \text{ W/Hz} \quad (3)$$

where: $N_L(f)$ is the laser intensity noise power per Hz;
 N_q is the photonic shot noise power per Hz;
 $N_{\text{th}}(f)$ is the contribution of thermal noise power per Hz;

Thermal and laser intensity noise vary with frequency. Shot noise is a function of the intensity of light incident on the photodiode.

Electronic tools are often used to determine lightwave system parameters. But, when actual electrical values are measured to determine optical parameters, care must be taken to include the effects of photodiode responsivity, the gain and noise effects of any amplifier present, and the frequency response corrections of each element.

While it is desirable to determine the total system noise, it is also valuable to determine separately the individual contributions of laser, shot, and thermal noise and to compare each to a total system noise budget. A discussion of each of these noise sources follows.

Thermal Noise

In a lightwave system, the amplifier and electronics that follow the photodiode produce thermal noise (N_{th}). Thermal noise limits the sensitivity of the receiver and restricts the distance between transmitter and receiver in both analog and digital systems. Thermal noise can be expressed in several ways. It is often described as a noise factor, or noise figure, expressed in dB relative to the room-temperature lower limit of -174 dBm/Hz.

To reduce the thermal noise contribution of the receiver, very low noise amplifiers are often added after the photodiode. As an example, electrical spectrum analyzers are often used in lightwave measurements. But as figure 1 shows, most electrical spectrum analyzers have noise figures of 30 dB or higher. Adding a preamplifier will improve the sensitivity of the analyzer by reducing the overall noise figure, and hence the ability of the analyzer to measure lightwave signals.⁴ Typical noise figures for amplifiers range from a few dB (above -174 dBm/Hz) for narrowband amplifiers, 6 to 8 dB for low-noise, wider-band amplifiers, to as much as 15 dB. Therefore, when choosing an amplifier, sensitivity often must be traded off for bandwidth.

Shot Noise

For a system at a given temperature, thermal noise is usually constant, but shot noise varies with average power. Shot noise (N_q) is produced by the quantum nature of photons arriving at the detector, and related detection statistics. The noise produced is related directly to the amount of light incident on the photodetector. The mean-squared noise current from the photodetector is:

$$\langle i_n^2 \rangle = (2qI_{dc}B) \quad (4)$$

where: q is the electron charge (1.60×10^{-19} coulomb);
 I_{dc} is the current out of the diode due to the average optical power input; and B is the electrical noise bandwidth of the measurement (typically normalized to 1 Hz).

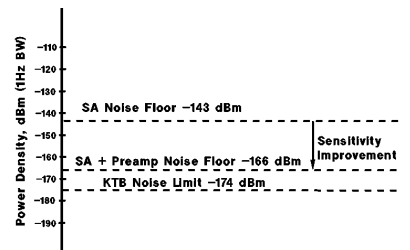

Figure 1. Noise limits in electrical systems are improved with a preamplifier.

The familiar equation $P=I^2R_L$, where R_L is the load resistance of the amplifier input, is used to convert this noise current into units of power. Therefore, the shot-noise power, N_q , in a one Hz bandwidth, becomes:

$$N_q = (2qI_{dc})R_L \quad (5)$$

For example, if the load resistance is 50 ohms, a photocurrent of 1 mA will generate a shot-noise power of -168 dBm/Hz ($1.6 \times 10^{-17} \text{ mW}$). As figure 2 shows, for each decade of photocurrent increase, the shot-noise power will increase 10 dB. In some systems, the light ($>0 \text{ dBm}$) striking the photodetector is enough to cause the shot noise to become larger than the thermal noise of the system.

Laser Intensity Noise

Laser intensity noise, N_L , refers to the noise generated by the laser. Laser intensity noise is caused by intensity fluctuations due primarily to spontaneous light emissions that are dependent on structural parameters of the laser. Operating conditions, such as bias level and modulation frequency, also directly affect the noise level.⁵ The presence of external feedback or reflections into the laser will increase this noise.⁶ As figure 3 shows, the dominant noise feature of the laser intensity noise is the intensity-noise peaking at the relaxation resonance point.

RIN Measurement Limitations

RIN is essentially a dynamic range measurement. It is a ratio of noise to average power. If the average power is reduced, the RIN measurement range is reduced. Figure 4 shows how measuring RIN as a function of the average power is limited by the thermal noise. If the average power incident on the detector becomes large enough, the shot noise overcomes the thermal noise and becomes the measurement limit. This shot-noise-limited condition will have the same noise value in any lightwave system.

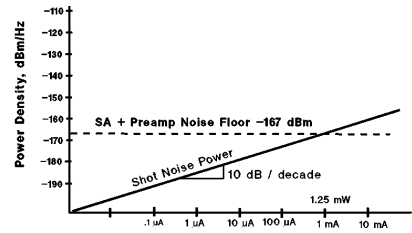
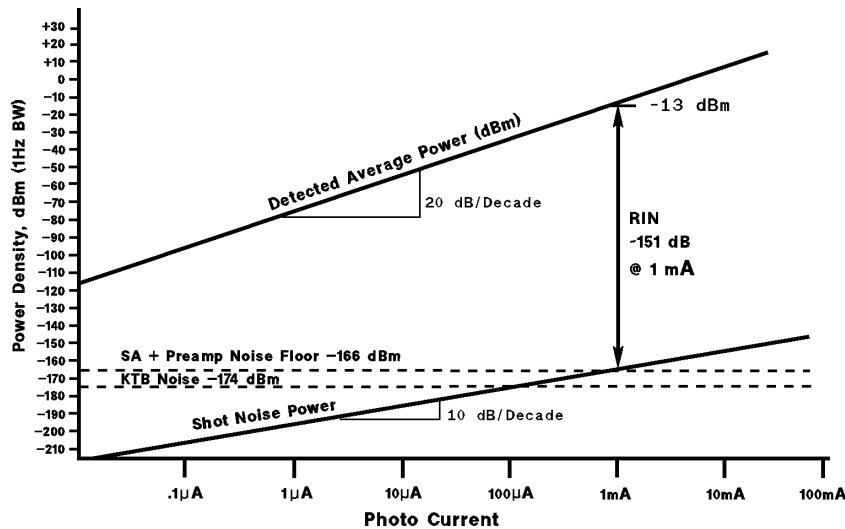

Figure 2. Shot noise increases with average power and can become larger than the thermal noise.

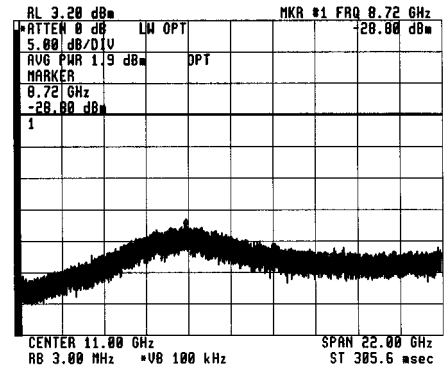

Figure 3. Laser intensity noise and the relaxation resonance point vary with laser bias level.

Figure 4. Direct RIN measurements are limited by the thermal noise, shot noise, and total detected power.

It is often valuable to determine error budgets for each component. This requires separating the laser-intensity-noise contribution from the rest of the system. For RIN measurements of the laser only, thermal and shot noise effects become unwanted “errors” and must be removed. To avoid confusion, laser-component RIN measurements are distinguished from system RIN measurements. RIN_{System} will refer to the total system measurement and RIN_{Laser} will refer to the RIN that results from only excess noise generated by the laser.

The value of the laser intensity noise is found from equation 3 by subtracting the values of shot and thermal noise from the total system noise:

$$N_L(f) = N_T(f) - N_q - N_{th}(f). \quad (6)$$

When the noise of the laser far exceeds the shot or thermal noise terms, the total system noise is essentially equal to the laser intensity noise. In such cases, RIN_{Laser} equals RIN_{System} . However, as laser quality improves and the intensity-noise level decreases, the effects of shot and thermal-noise sources become more significant in RIN measurements. The contribution of any one of the three noise terms will dominate if it is approximately 5 to 10 dB larger than the other terms. As equation 3 shows, the total noise is a summation of these three noise terms.

An example of a system dominated by laser intensity noise is provided by measurements made on a typical 1-mW Fabry-Perot laser. The total system noise (N_T) was measured at -145 dBm/Hz, the thermal noise (N_{th}) was -168 dBm/Hz, and the shot noise (N_q) is -169 dBm/Hz (for $I = 0.8$ mA). Converting to linear terms and subtracting the shot and thermal noise from the total gave the laser intensity noise. It was only 0.04 dB less than the total system noise. For this typical Fabry-Perot laser, the total system noise is almost exclusively composed of laser intensity noise. For shot and thermal noise values to contribute more than 1 dB to the total noise power, the excess laser intensity noise would have to be reduced 15 dB to about -160 dBm/Hz. Thus, improving this system performance only requires the laser performance be addressed.

Finding RIN_{Laser} from RIN_{System}

RIN is the ratio of noise power to average power. Equations 2 and 3 can be used to determine the value of RIN_{Laser} .

$$RIN_{System} = \frac{N_T}{P_{AVG}} = \frac{N_L}{P_{AVG}} + \frac{N_q}{P_{AVG}} + \frac{N_{th}}{P_{AVG}} \quad (7)$$

Subtracting thermal and shot noise effects from the total allows the excess noise of the laser to be determined.

$$RIN_{Laser} = \frac{N_L}{P_{AVG}} = RIN_{System} - \frac{N_q}{P_{AVG}} - \frac{N_{th}}{P_{AVG}} \quad (8)$$

Thermal noise can be calculated from the noise figure specified for the measurement system. Shot noise and average power are functions of the average current from the photodiode. The average current can be determined from measured average power. The average electrical power at the amplifier input, written in terms of I_{dc} is $P_{AVG} = I_{dc}^2 R_L$. (See table A1 in appendix A.)

Using equation 5, the shot noise ratio becomes:

$$\frac{N_q}{P_{AVG}} = \frac{(2qI_{dc}R_L)}{I_{dc}^2 R_L} = \frac{2q}{I_{dc}} . \quad (9)$$

Equation 8, for the RIN of the laser (in a 1 Hz bandwidth), becomes:

$$RIN_{Laser} = RIN_{System} - \frac{N_{th}}{P_{AVG}} - \frac{2q}{I_{dc}} . \quad (10)$$

Using table A1 in appendix A to write P_{AVG} and I_{dc} in units of the more easily measured optical power:

$$P_{AVG} = (r P_{AVG(opt)})^2 R_L; \text{ and } I_{dc} = r P_{AVG(opt)} .$$

Substituting, equation 10 becomes:

$$RIN_{Laser} = RIN_{System} - \frac{N_{th}}{R_L (r P_{AVG(opt)})^2} - \frac{2q}{r P_{AVG(opt)}} \quad (11)$$

Use Equation 11 to determine the RIN of the laser.

Figure 5 is a plot of RIN_{Laser} against RIN_{System} to show the effect of subtracting the thermal and shot noise with varying average power, assuming a fixed value of thermal noise (8 dB NF) and responsivity (0.8 A/W or 40 V/W into 50 ohms). The figure shows that when the total measured noise is greater than the thermal and shot noise terms by about 5 to 10 dB, the values of RIN_{System} and RIN_{Laser} are essentially equal.

Small Errors May Cause Large Effects

Great care must be taken when using this subtraction method to determine RIN_{Laser} . In subtracting small numbers from small numbers, errors in values that are close to the excess-noise value of the laser can have large effects. Errors in the amplitude accuracy of the frequency response of the diode can also cause exaggerated effects. It is important to know the frequency response for the total system before making noise subtractions. The calibrated accuracy of the Agilent 71400C system allows a greater range of subtraction than would be possible without the calibration.

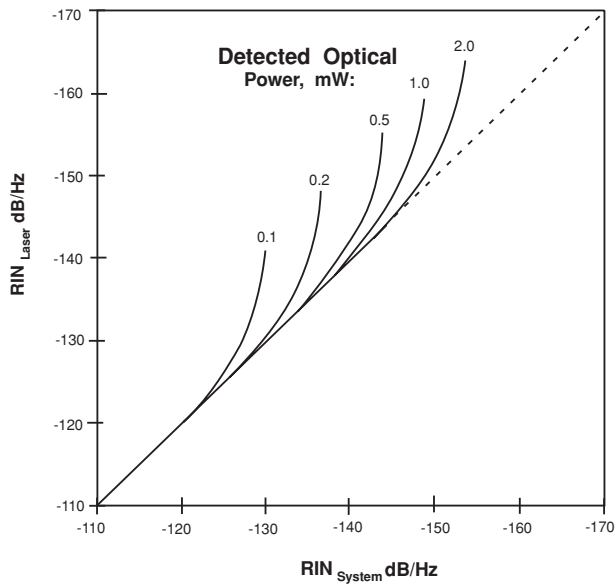

Figure 5. RIN_{Laser} calculated from the measured RIN_{System} , versus average power.

Chapter 2 will describe measurements of RIN_{System} and RIN_{Laser} performed using the Agilent 71400C lightwave signal analyzer. The tables in chapter 2 summarize the specified RIN_{System} and RIN_{Laser} capabilities of the Agilent 71400C lightwave analyzer for various frequency ranges. With the correction factors available in the analyzer, subtraction of the thermal-noise and shot-noise terms will provide up to an additional 16 dB range for measurements of RIN_{Laser} . A downloadable program for the Agilent 71400C that automatically performs these subtractions and computes RIN_{Laser} will be described in the next chapter.

Summary

Work on improving laser intensity noise continues. In some cases, the intensity noise levels of the laser can approach the noise limitations of measurement system. To evaluate laser-intensity noise contributions and limitations, the relative-intensity-noise specification, RIN, was developed. This measurement is the ratio of the laser intensity noise to the average power of the laser, in equivalent electrical units. This chapter described some limits to measuring the noise contribution of the laser and a discussed how to remove the shot-noise and thermal-noise components associated with determining the RIN of the laser.

References

- ¹ K. Y. Lau and A. Yariv, "Ultra-High Speed Semiconductor Lasers," *IEEE J. Quantum Elect.*, QE-21, NO.2, pp. 121–136, February 1985.
- ² C. M. Miller, "Intensity Modulation and Noise Characterization of High-Speed Semiconductor Lasers," *IEEE LTS*, pp. 44–52, May 1991.
- ³ G. P. Agrawal and N. K. Dutta. *Long-Wavelength Semiconductor Lasers*, pp. 248. AT&T Laboratories, New York: Van Nostrand Reinhold, 1986.
- ⁴ See Application Note 150, Hewlett-Packard Publication no. 5952-0292, and Appendix A of Application Note 371.
- ⁵ H. Sobol, "The application of microwave in lightwave systems," *J. Lightwave Technology*, vol. LT5, pp. 293–299, March 1987.
- ⁶ J.L. Gimlett and N.K. Chenug, "Effects of phase-to-intensity noise conversion by multiple reflections on gigabit-per-second DFB laser transmissions systems," *J. Lightwave technology*, vol. 7, pp. 888–895, June 1989.

Chapter 2

Measure Relative Intensity Noise with the Agilent 71400C and 71401C

This chapter presents measurements of relative intensity noise (RIN) performed specifically with the Agilent 71400C and 71401C lightwave signal analyzers that contain the Agilent 70810B lightwave section.¹ Examples and limitations are discussed, along with guidelines for setup, measurement, and operation of the two RIN measurement functions that are built into these lightwave signal analyzers.

Agilent 71400C and 71401C Lightwave Signal Analyzers

The Agilent 71400C and 71401C lightwave signal analyzers were designed to facilitate development and testing of fiber-optic communications systems and components. The analyzers measure important lightwave characteristics such as signal strength, modulation bandwidth, signal distortion, effects of reflected light, and noise. Used with the Agilent 11980A fiber-optic interferometer, the Agilent 71400C and 71401C can also measure linewidth, chirp, and frequency modulation of single-frequency lasers. The Agilent 71400C operates over the frequency range of 100 kHz to 22 GHz, while the Agilent 71401C covers the frequency range of 100 kHz to 2.9 GHz. The lightwave signal analyzers have internal correction and calibration that allow them to display optical measurements with ± 1 dB accuracy across their full bandwidth. Both contain the same features and functions, including operation as high-performance electrical spectrum analyzers.

The Agilent 70810B Lightwave Converter

The Agilent 70810B lightwave section serves as the key component of the Agilent 71400C and 71401C lightwave signal analyzers and covers the optical wavelength range from 1,200 nm to 1,600 nm. As figure 6 shows, the Agilent 70810B is comprised of a broadband PIN photodiode, internal optical attenuator, electrical preamplifier for improved sensitivity, and an optical power meter.

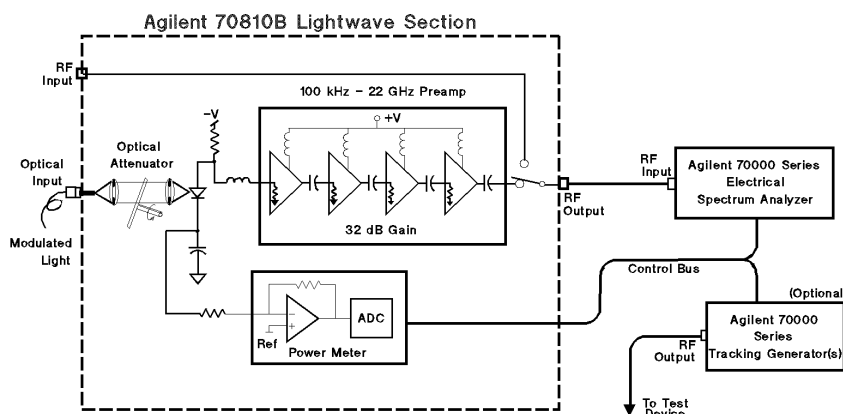

Figure 6. Block diagram of the Agilent 71400C lightwave signal analyzer.

¹ The Agilent 70810B module is an update that allows down-loadable programs (DLP). The RIN function discussed in this chapter is such a DLP. If you have a system with an Agilent 70810A module, please contact your Agilent Technologies representative for upgrade details.

The optical power meter provides both digital annotation and analog graphical readouts. It can display information in either optical or electrical units, independent of the units selected for the trace display. The chosen reference level on the display is also used as the reference level for both the power bar and the trace. This shared reference level allows for visual checks of the dynamic range of the laser (average-power to noise) and relative modulation levels over the full bandwidth of the laser.

With the power meter built-in, there is no need to change connections between an external power meter and the signal analyzer for measurements that require both instruments. Not having to change connections removes connector uncertainty for relative measurements. The factory provides calibration at both 1300 nm and 1550 nm, selectable from the menus. The power meter also may be calibrated to a transfer standard. If adjusted, all amplitude readouts, including the modulation measurements, will reflect the new reference.

Noise Measurements

The lightwave signal analyzer has three noise functions built in: marker noise; RIN_{System} ; and RIN_{Laser} . Marker noise is used to measure the absolute noise value at a selected frequency in either optical or electrical units. The two RIN functions make use of the built-in average power meter. Relative intensity noise of the laser describes the maximum amplitude range available for signal modulation.

Marker Noise

Marker noise reads the average value of the noise present at the marker location, normalized to a 1-Hz bandwidth. This measurement is selected using **MKNOISE** on page 2 of the marker menu. For measuring a lightwave signal, either optical units, referenced to the optical input, or electrical units, referenced to the output of the photodiode, are available. Marker noise adjusts for equivalent noise bandwidth, incorporates proper sample-detection methods, averages 32 points around the marker, and normalizes the result to a 1-Hz bandwidth.

System RIN measurements

RIN_{System} — the measurement that includes excess laser intensity noise, the detection shot noise, and the thermal noise of the instrument — is provided in the Agilent 71400C or 71401C by the function **RIN SYS**, found in the marker menu. This function utilizes the built-in power meter, amplifier, lightwave corrections, and the marker-noise function to compute the ratio of the total noise and average optical power. The answer is returned as the ratio of equivalent electrical terms, as in equation 2 of chapter 1, regardless of which units are displayed. For example, in figure 7 the analyzer shows both the average power readout and trace display in optical units. Pressing **RIN SYS** gave -141 dB/Hz, the electrical ratio.

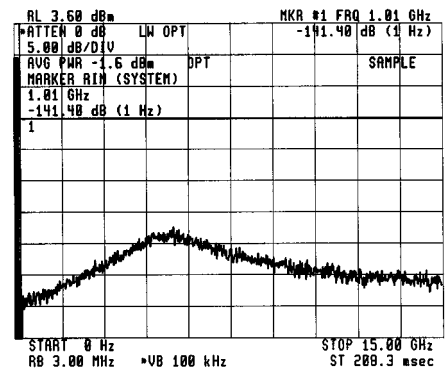

Figure 7. RIN_{System} display.

² For more information on noise measurements see Application Note 150, pp 31–34.

To use this function, set up the display for the desired bandwidth and marker location before pressing **RIN SYS**. After engaging the function, the marker is active and it may be moved to determine RIN_{System} at various locations in the noise response of the laser.

A wide span is useful for viewing the full response of the laser and for determining frequencies for optimum system operation and signal-to-noise. However, reducing the span to about 400 MHz, centered around a frequency location of interest, can reveal the presence and degree of reflection ripples (Fabry-Perot resonances) in the system.³ Reducing the video bandwidth (**VID BW**) will help determine the average noise value. This marker function is usually adequate for determining RIN of most Fabry-Perot lasers.

Measurement Limits of RIN_{System}

With a 0-dBm (1 mW) laser, **RIN SYS** is limited to about -145 dB/Hz.⁴ The average CW power of the laser determines the upper limit. Thus, the measurement limit of **RIN SYS** is determined by the available power of the laser and the noise floor (thermal plus shot) of the specific analyzer used. It is best to measure the noise floor of the actual analyzer (to avoid the guard-bands necessary to account for wide temperature ranges and other module-to-module variations). However it is possible to use the published sensitivity specifications for the analyzer to determine a generic RIN measurement limit.

At the limit, the system can receive up to 3 dBm of optical power before requiring attenuation. Although the internal attenuator allows power levels up to 30 dBm, adding attenuation decreases the sensitivity of the analyzer. Thus, with 3 dBm of optical power on the photodiode, and the attenuator set to 0 dB, the Agilent 71400C achieves its best RIN range, determined from the data sheet, of -149 dB/Hz (including the shot noise term). Table 1 lists various Agilent 71400C specification limits in the three key frequency ranges for three average power values.

Frequency Range	+3 dBm Power	0 dBm Power	-5 dBm power
10 MHz-100 MHz	-141 dB/Hz	-135 dB/Hz	-125 dB/Hz
100 MHz-16 GHz	-149 dB/Hz	-143 dB/Hz	-133 dB/Hz
16 GHz-22 GHz	-137 dB/Hz	-131 dB/Hz	-121 dB/Hz

Table 1. RIN_{System} limits for the Agilent 71400C from system specification

Laser RIN Measurements

RIN_{Laser} is the ratio of the laser noise to average power, with the shot and thermal noise terms removed. Since all receivers have shot and thermal noise, RIN_{Laser} is determined by subtracting the excess noise terms, as described in chapter 1. The Agilent 71400C and 71401C provides this capability with a RIN measurement personality (one of several downloadable programs (DLPs) available from Agilent Technologies). While the RIN personality is built into the system, it is also provided on a ROM card and a disk, for backup in case the program is erased.⁵

³ For more information see Application Note 371, chapter 3.

⁴ Based on displayed average noise specifications of the Agilent 71400C.

⁵ See appendix B for instructions on loading a DLP into the MMS system.

Measurement Limits of RIN_{Laser}

Measurements made with the RIN DLP are subject to the same basic limits as the **RIN SYS** function: average power and the noise floor of the analyzer. However, the DLP subtracts the contributions of shot and thermal noise up to a limit of 16 dB over the value obtained with the **RIN SYS** function. The limit is imposed because small numbers are subtracting from small numbers. An error in one term can cause disproportionately large errors in the results if pushed beyond the capabilities and calibration of the analyzer. If this limit is encountered, a superscript “+” symbol will be displayed after the RIN (laser) value, indicating that the instrument has reached its measurement limits and the RIN_{Laser} is this displayed value or better. Even with this limit placed on the measurement, there can be considerable accuracy variations (3–6 dB is not uncommon at low RIN values). Table 2 gives possible RIN_{Laser} values, calculated from specification limits.⁶

Frequency Range	+3 dBm Power	0 dBm Power	-5 dBm power
10 MHz–100 MHz	-157 dB/Hz	-151 dB/Hz	-141 dB/Hz
100 MHz–16 GHz	-165 dB/Hz	-159 dB/Hz	-149 dB/Hz
16 GHz–22 GHz	-153 dB/Hz	-147 dB/Hz	-137 dB/Hz

Table 2. RIN_{Laser} limits, using the RIN personality, in the Agilent 71400C from system specifications

The actual value of these limits will vary from system to system, based on actual thermal-noise values. For example, a best case module with an actual thermal-noise floor of -166 dBm/Hz could have a RIN_{Laser} limit of -170 dB/Hz (with the 3-dB maximum photodiode illumination). Lower average power inputs will correspondingly lower the RIN measurement capability. For the module in this example, a laser with -0 dBm input power will lower the RIN measurement limit to -165 dBm. The graph in figure 8 summarizes these measurement limits. The graph plots the characteristic RIN personality limits (calculated) along with the **RIN SYS** limits as a function of average power. It also plots the thermal and shot noise contributions.

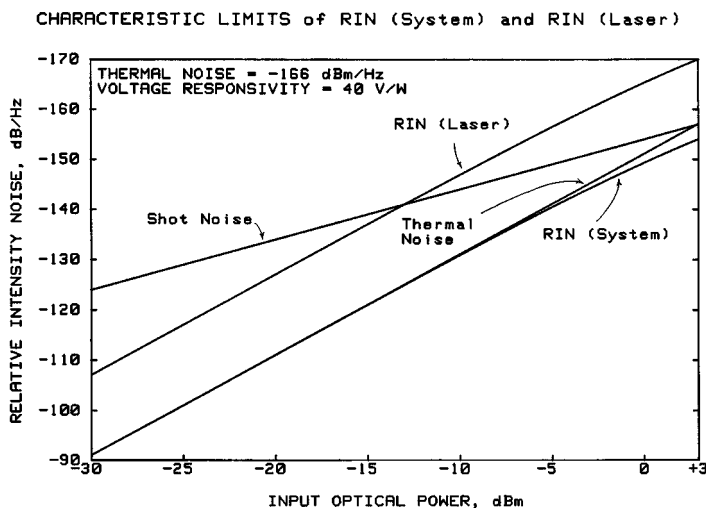

Figure 8. Typical Agilent 71400C measurements limits for RIN_{System} and RIN_{Laser}, given a noiseless laser.

⁶ Specifications subject to change.

For best measurement results (short-term thermal noise stability) on low RIN values, choose the largest resolution bandwidth (**Res BW**) and the lowest video bandwidth (**Vid BW**) available.⁷ This combination results in a thermal noise measurement, short-term stability, of about 0.02 dB. A narrow span (100 MHz for example) will speed up the trace sweep time. Larger video bandwidths may be used to increase the measurement speed if the RIN values are more than a few dB above the thermal-noise limit. See figure 13.

RIN Variability

While RIN serves as a quality indicator of laser devices, it is not a static parameter. Determining static, or unmodulated, RIN values is often not enough to determine system requirements. Modulating the laser or changing other parameters, such as reflections, can greatly effect RIN. The effects of modulation and other system parameters on RIN can be readily observed on the screen, and action can be taken to reduce any problem uncovered. For example, figure 9 shows the intensity noise of a well-isolated laser, with and without modulation applied.

Using the RIN Measurement Personality

To use the RIN DLP, configure the instrument as you would use the **RIN SYS** marker function; that is, adjust the stop and start frequency as desired, select the video bandwidth desired, and put the marker on the frequency of interest. Select as low an attenuation as possible, allowing no more than 3-dBm optical power to reach the photodiode. The instrument checks for too much or too little power and indicates **over range** or **under range** as required.

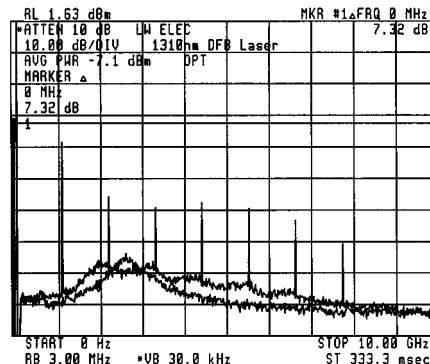

Figure 9. Modulation affects laser intensity noise.

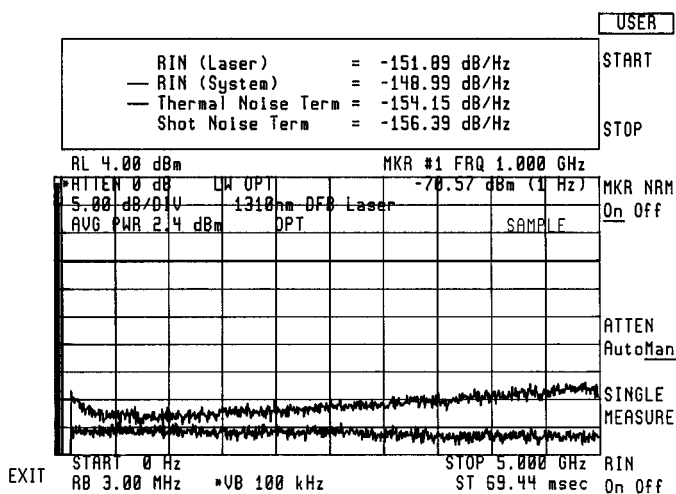

Figure 10. Typical display resulting from the Laser RIN personality.

The RIN measurement personality is accessed under the **USER** menu key and is activated by pressing the **RINLasr** softkey. Running this program decreases the size of the display to allow room for a new data window, as shown in figure 10. This data window displays four lines of information. The top line gives the desired RIN_{Laser}

⁷ This is: 3 MHz Res BW and 300 Hz Vid BW for systems containing the Agilent 70903 IF module.

value without the thermal-noise or shot-noise terms. The second line provides the RIN_{System} value, which is the same number that the **RIN SYS** function (under the marker menu) would give. The third and fourth lines present the thermal-noise and shot-noise contributions that are subtracted to obtain the Laser RIN. These four terms are the same as those in equation 11, chapter 1. Note that although the total shot noise increases with more average power, the shot noise term decreases.

The program is not a simple function; changing any parameter will halt the program and the **RIN** key will go from the **on** state to the **off** state. However, the DLP maintains the window setup. The start, stop, marker, and attenuation keys are readily available from the DLP menu. If you wish to use other functions, press the **MENU** key, select and execute the desired function, and then press the **USER** key again. Reactivate the RIN_{Laser} calculations again by pressing the **RIN on** key. If you want to exit the DLP, press the **exit** key (also in the DLP menu). The RIN function will terminate and the display will return to normal.

The personality indicates the state of the measurement values by brightness. As the DLP is first activated, the data values will be blank. As soon as the program acquires sufficient measurement information, the values will appear in the window, with the RIN_{Laser} value displayed brighter than the contributing terms. If the RIN program is halted (by pressing any key, or changing the marker), the data update is stopped and all numeric values dim. The last measured values remain displayed until either the RIN measurement is turned back on, and sufficient data is again obtained, or the program is exited.

The RIN personality operates by taking two sweeps, one with the laser on and one with the light from the laser blocked. The first sweep measures the average power and total noise of the laser. This is displayed in trace A. The second sweep blocks the light and measures the thermal noise of the analyzer and places it in trace C. Both procedures are visible while the program is running. Halting the program will blank trace C, leaving trace A active. A single-measure key can be pressed that will cause the analyzer to take one sweep, update the data window, and leave both static traces displayed. This function is useful when a plot is desired of both traces. Trace C may also be turned on or off from the **trace** menu.

Example 1: DFB Laser

Figure 11 shows the RIN DLP measurement results for a distributed feedback (DFB) laser and the effects of attenuation on the measurement. The laser had less than 2 mW (3 dBm) of average power, so 0 dB attenuation was entered. The DLP measured the RIN of the laser to be -152 dB/Hz, while the RIN_{System} was -149 dB/Hz.

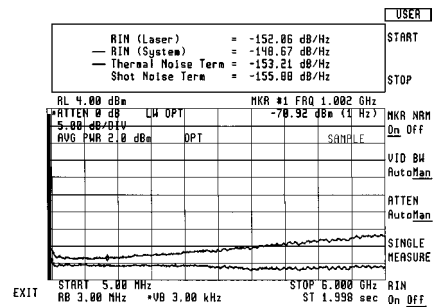

Figure 11. DFB laser

In figure 12, we added 5 dB of optical attenuation (10 dB electrical) to the laser. The thermal noise rose 10 dB and the RIN_{System} degraded to -143 dB/Hz. But, the computed RIN_{Laser} differed by just 0.7 dB. For this measurement we reduced the video bandwidth for thermal noise stability which resulted in an increase in the sweep time.

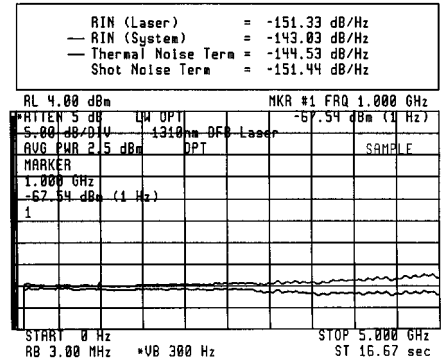

Figure 12. DFB laser with 5 dB attenuation added.

Example 2: Fabry-Perot Laser

Figure 13 shows a Fabry-Perot laser that was measured using the RIN Personality. This laser has sufficient intensity noise that the RIN_{System} function gives the same results as the RIN_{Laser} . Using the DLP is not necessary. The **RIN SYS** marker function should be used rather than the DLP because it performs the RIN measurement much faster, and it has the ability to move the marker location while the RIN measurement is in progress.

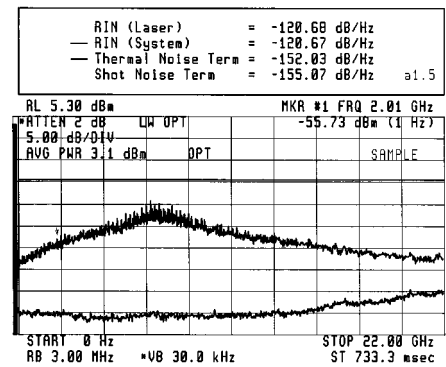

Figure 13. Fabry-Perot laser

Example 3: Mini-YAG Laser

Figure 14 shows a measurement of a mini-YAG laser performed using the DLP. The laser has a large power output, requiring optical attenuation to keep the incident light on the photodiode to the 3 dBm limit. With added attenuation the shot noise is not determined by the total power of the laser, but rather by the total power of the light illuminating the photo diode. The DLP is able to determine correctly the proper shot-noise contribution and change in thermal noise due to the attenuation, and determine the RIN value of the laser (up to a limit of 16 dB better than the value found by **RIN SYS**). Because of the low RIN value, the resolution and video bandwidths have been set to optimize the noise measurement stability.

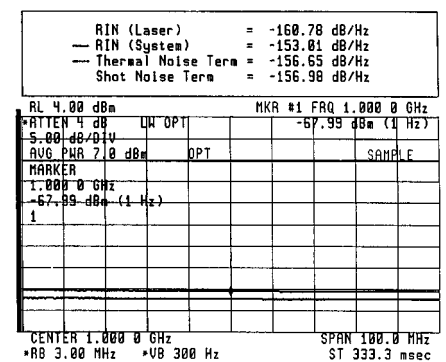

Figure 14. Mini-yag laser

Appendix A

Electrical-Optical Relationships

Conversion between optical and electrical values must take into account the specific values of responsivity, load resistance, and gain of the converter. A simple 2:1 conversion ratio is not sufficient. The equations presented in Table A-1 are for convenience.

Relationship Between Optical and Electrical Powers

The detected output current from the photodetector is a linear replica of the optical power input. A 1-dB change in optical power to the photodetector will produce a 2-dB change in the output electrical power.

Converting from optical to electrical power is easy if you know the responsivity and the load resistance. However, the electrical output power will further be offset by the gain of any amplifier present. Table A-1 summarizes these relationships.

Note that voltage responsivity, r_v , is commonly given at the reference plane of the photodiode. However, if an amplifier is integral to the converter, as in the case of the Agilent 11982A, the responsivity is given from the reference plane located after the amplifier. For these cases, the equation for responsivity should include the gain, G_v , of the amplifier: $r_v = rG_vR_L$ (rather than as given below.)

	Relationship	Units
Optical Power	$P_{AVG(opt)} = (R_L P_{AVG})^{1/2} r_v$	watts
Responsivity	$r = r_v / R_L$	amps/watt
Electrical Gain	G_v	volts/volt
Responsivity (voltage)	$r_v = r R_L$	volts/watt
Detected Current	$I_{dc} = r P_{AVG(opt)}$	amps
Detected Voltage	$V_d = I_{dc} R_L$ $= r R_L P_{AVG(opt)}$	volts
Amplified Voltage	$V_{dc} = r G_v R_L P_{AVG(opt)}$	volts
Average Electrical power	$P_{AVG} = I_{dc}^2 R_L$ $= (V_d)^2 / R_L$ $= R_L (r P_{AVG(opt)})^2$ $= (r_v P_{AVG(opt)})^2 / R_L$	watts
Modulated Electrical Power	$P_M = 1/2 (r_v P_{M(opt)})^2 / R_L$	watts

Table A-1.

Appendix B

Personality Installation and Removal

This appendix describes the Agilent 70810B laser RIN measurement personality. It tells how to recall the personality firmkey, if over-written, and how to load the personality into the instrument from either the ROM card or floppy disk.

What is a Measurement Personality?

A **measurement personality** is a downloadable program consisting of measurement routines especially useful to a particular application. A **downloadable program (DLP)** is a software routine written with an external computer and **downloaded** (stored) into non-volatile RAM in an instrument (in this case, the Agilent 70900 LO). Several DLPs will fit into instrument memory simultaneously. However, too many installed DLP's can use up the available memory, which limits the ability of the analyzer to save instrument states, setups, or traces. Once downloaded, the DLP can be executed at the press of a softkey from the USER menu, without an external computer.

The **Laser RIN Personality** is a DLP that measures the relative intensity noise of a laser. The RIN DLP may be removed (erased) to make room for other DLPs or trace storage by **purging** the two files that are in the system memory. If the personality is accidentally erased, it can be reloaded into the instrument; if the key assigned (in the **USER** menu) is overwritten, it can be reassigned using the procedures described in this appendix.

System Requirements

To load a DLP into the Agilent 71400C lightwave signal analyzer, an Agilent 70900B local oscillator must be configured into the system. For the RIN DLP to be loaded, the Agilent 70900B must have a date code of 910701 (July 1, 1991) or later. An Agilent 70810B lightwave section must also be configured into the system. The Agilent 70810B must be operating in a "slave" configuration to the "master" Agilent 70900B. Released earlier, Agilent 70810A modules do not allow DLP applications and must be updated to permit usage with a DLP.

Reloading the Personality from the ROM Card

Following are the steps and key sequences used to load the Agilent 70810B laser RIN measurement personality into the Agilent 71400C from a ROM card.

Insert the ROM card, face up and arrow end first, into the slot on the Agilent 70004A display/mainframe. Press the MENU hard key on the instrument. Then follow the menu selection sequence:

Press **Misc, more 1 of 3, Catalog & MSI.**

The trace display will shrink and the list of the current "Mass Storage Is" assignment will be given as in figure B-1.

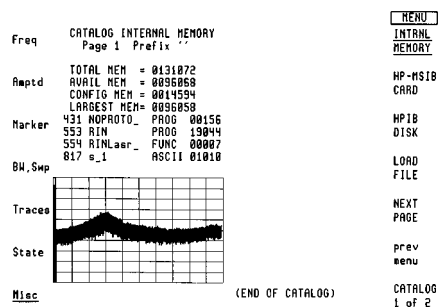

Figure B-1. Display when selecting "Mass Storage Is" assignment will be given as in figure B-1.

Press the **HP-MSIB CARD** key for the catalog of the ROM card.

Note: If you do not get a catalog of the memory card or if you get a “storage device error” message, check the following:

Make sure the card is firmly seated in the slot. The number displayed after pressing **HP-MSIB CARD** must match the MSIB column address of the Agilent 70004A display. If it does not, enter the proper column address (with the numeric keypad).

If the problem persists, set the “Mass Storage Is” selector of the Agilent 70004A display to the memory card. To set, press: **DISPLAY, Mass Storage, MSI** and **MEMORY CARD**. To return to the catalog display, press the **MENU** key and go back to the **HP-MSIB CARD** selection (through the **Misc** menu).

Locate the DLP to be added to the instrument and determine its file number.

Press **LOAD FILE** and enter the file number of the DLP using the numeric keys followed by the **ENTER** key.

The system will read the program from the card, load it into the instrument memory (if there is sufficient room), and assign the DLP to a blank key on the **USER** menu. Note that a new DLP or file will replace an old file of the same name. For additional information, see the “User-Defined Softkey Descriptions” section of chapter 3 in the operation manual for the Agilent 70900 local oscillator.

Retrieving the DLP Execute Key from a User Overwrite

For user convenience, it is possible to place any menu *function* into the user menu, including overwriting the key labeled with a DLP, with the **DEFINE USR KEY**. This key reassignment does not erase the DLP. To recall the user key to the default assignments, including the labeling of keys for DLPs currently in internal memory, press **Misc** menu, **more**, **key control**, **PRESET USER**.

Erasing a DLP from the Instrument’s Memory

A DLP or file may be removed from the instrument’s memory by pressing the **Misc**, **more**, **Catalog & MSI**, and **INTRNL MEMORY** keys to get to the list of files in the memory. Select the file to be removed (using **next page** if necessary) and note its assigned file number. Then press **more**, **PURGE FILE** and **ENTER** the file number to be erased (see figure B-2). Many DLPs may have more than one file that need to be removed. The RIN DLP has two files.

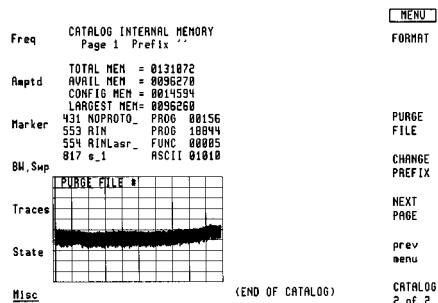

Figure B-2. Display seen when deleting files.

Reloading the Personality from the Floppy Disk

The DLP may also be loaded into the instrument memory with an external GPIB floppy disk drive and the supplied disk. The following equipment is required:

- GPIB disk drive with 3.5 inch, CS80 compatible, floppy media, such as the Agilent 9122
- GPIB cable to connect from the disk drive to the Agilent 70004 or 70001 manframe
- Agilent 70900 local oscillator module
- Agilent 70810B lightwave module
- Laser RIN Personality floppy disk

Find the GPIB address of the disk drive. Connect it to the GPIB socket on the frame (Agilent 70004 display or 70001 mainframe) that contains the Agilent 70900 local oscillator module. Disconnect any external computers from this same GPIB line, as there can only be one controller on the MMS Bus at a time. Press the **MENU** key and then press:

Misc, more, Catalog & MSI. The instrument's trace display will shrink and the list of the current "Mass Storage Is" assignment will be presented as in figure B-1.

Press the **GPIB disk** key for the catalog of the floppy disk.

Note: If you do not get a catalog of the floppy disk, check that the number displayed after pressing **GPIB DISK** matches the GPIB address and unit number of the external disk drive. The unit number is entered with the GPIB address, separated by a period, with the numeric keypad. (Typically a dual floppy disk references the left drive as "0" and the right drive as "1." A hard disk/floppy device typically references the floppy drive as "1.")

Locate the DLP to be added to the instrument and determine its file number.

Press the **LOAD FILE** key and enter the file number of the DLP.

The system will download the program from the disk into the instrument memory, if there is sufficient room, and assign the DLP to a blank key on the USER menu.

Appendix C

Remote RIN Commands

This appendix contains the remote, or programming, commands to operate the two RIN functions of the Agilent 70810B lightwave section. These commands are different than the remote command for RIN that is supported by the Agilent 70810A module. For additional information on syntax, parameters, or functions, refer to the Agilent 70900 Local Oscillator Programming Manual. The Agilent 70900 is the controller and system master for Agilent 71400C and 71401C systems that contain the Agilent 70810B module.

Agilent 71400C and 714001C lightwave analyzers containing the Agilent 70810B module have two RIN functions available. The first is available in the marker menus. The second is a downloadable program (DLP); see appendix B. Both functions are accessible by remote commands. Prior to introduction of the Agilent 70810B module, the Agilent 70810A module measured only RIN_{System} with the remote command **MKRIN**. Programs written for these older modules will need to change any **MKRIN** command used to allow operation with the Agilent 70810B module. Following are the RIN Agilent 70810B commands.

RIN_{System} Agilent 70810B function

Menu function: **RIN SYS**

Remote command: **MKRINSYS**
ON
OFF
Freq units
UP
DN

For example the command **MKRINSYS 1 GHz** will place the marker at 1 GHz and activate **RIN SYS**. Following the RIN command, an **MKA?** command will return the value of the marker, RIN_{System} . The arrow commands, **DN** and **UP**, are also available. Results will always be returned as the ratio of the electrical values.

RIN_{Laser} DLP

A downloadable program (DLP) is provided with each Agilent 70810B module for determining RIN_{Laser} .

The DLP must be loaded into the instrument. Adjust the instrument to the required settings (such as frequency location, resolution bandwidth, video bandwidth, and marker location) before the DLP is run. The **RIN?** command will activate the program, run a single measurement, and return the following four values in order:

RIN_{Laser} , RIN_{System} , thermal noise *term*, and shot noise *term*.

Futher infromation maybe obtained from the system programming manual.

Example:

Measure the value of RIN_{Laser} at the current marker location and with current instrument settings.

```
10  OUTPUT 718; "RIN?"
20  ENTER 718; A,B,C,D
30  IMAGE K,SDDD.DD, " dB/Hz"
40  PRINT
50  PRINT USING 30; "RIN (Laser)      = ";A
60  PRINT USING 30; "RIN (System)    = ";B
70  PRINT USING 30; "Thermal Noise Term = ";C
80  PRINT USING 30; "Shot Noise Term  = ";D
90  END
```

```
RIN (Laser)      = -150.41 dB/Hz
RIN (System)     = -146.40 dB/Hz
Thermal Noise Term = -150.02 dB/Hz
Shot Noise Term  = -154.15 dB/Hz
```

Figure C-1. Program listing

For more information about Agilent Technologies test and measurement products, applications, services, and for a current sales office listing, visit our web site,

www.agilent.com/comms/lightwave

You can also contact one of the following centers and ask for a test and measurement sales representative.

United States:

Agilent Technologies
Test and Measurement Call Center
P.O. Box 4026
Englewood, CO 80155-4026
(tel) 1 800 452 4844

Canada:

Agilent Technologies Canada Inc.
5150 Spectrum Way
Mississauga, Ontario
L4W 5G1
(tel) 1 877 894 4414

Europe:

Agilent Technologies
Test & Measurement
European Marketing Organization
P.O. Box 999
1180 AZ Amstelveen
The Netherlands
(tel) (31 20) 547 2000

Japan:

Agilent Technologies Japan Ltd.
Call Center
9-1, Takakura-Cho, Hachioji-Shi,
Tokyo 192-8510, Japan
(tel) (81) 426 56 7832
(fax) (81) 426 56 7840

Latin America:

Agilent Technologies
Latin American Region Headquarters
5200 Blue Lagoon Drive, Suite #950
Miami, Florida 33126, U.S.A.
(tel) (305) 267 4245
(fax) (305) 267 4286

Australia/New Zealand:

Agilent Technologies Australia Pty Ltd
347 Burwood Highway
Forest Hill, Victoria 3131, Australia
(tel) 1-800 629 485 (Australia)
(fax) (61 3) 9272 0749
(tel) 0 800 738 378 (New Zealand)
(fax) (64 4) 802 6881

Asia Pacific:

Agilent Technologies
24/F, Cityplaza One, 1111 King's Road,
Taikoo Shing, Hong Kong
(tel) (852) 3197 7777
(fax) (852) 2506 9284



Technical data subject to change
Copyright © 1991, 1996, 2000
Agilent Technologies
Printed in U.S.A. 7/00
5091-2196E



Agilent Technologies

Innovating the HP Way